



## ES SERIES 50-60 HZ

5" STAINLESS STEEL CLOSE-COUPLED  
SUBMERSIBLE MULTISTAGE ELECTRIC PUMPS





# INDEX

<b>5" Stainless steel close-coupled submersible multistage electric pumps .....</b>	<b>2</b>
Features and benefits.....	2
Family curves.....	3
Pump identification code.....	4
General features.....	5
<b>Spare parts and materials .....</b>	<b>6</b>
<b>Performance selection .....</b>	<b>7</b>
<b>Technical data and performance curves at 50 Hz.....</b>	<b>9</b>
Hydraulic performance.....	9
ES 3 .....	10
ES 5 .....	12
<b>Technical data and performance curves at 60 Hz .....</b>	<b>15</b>
Hydraulic performance.....	15
ES 3 .....	16
ES 5 .....	18
<b>Ordering information .....</b>	<b>20</b>

NOTE: Franklin Electric S.r.l. reserves the right to amend specification without prior notice

For the most up-to-date product information, visit [franklinwater.eu](http://franklinwater.eu).

# 5" STAINLESS STEEL CLOSE-COUPLED SUBMERSIBLE MULTISTAGE ELECTRIC PUMPS

## FEATURES AND BENEFITS

### APPLICATIONS



Water Distribution Pressure Boosting



Rainwater Recovering



Irrigation, Gardening, Sprinklers



Wash down unit



Slightly corrosive liquids



Water supply to and from tanks, reservoir and wells

### COMPACT CLOSE-COUPLED DESIGN

- Easy installation: the single-phase version have internal capacitor and thermic motor-protection thus is not necessary to connect the electric pump to a control panel
- Compact close-coupled design, robust and corrosion resistant
- Plug-in type power cable and level control (float) for easy replacement
- Motor cooling is guaranteed by the pumped liquid
- Continuous operation either in vertical or horizontal position

### HIGH QUALITY MATERIALS

- Heavy duty over size motor shaft
- Stainless steel water proof capsule to protect the motor
- Double mechanical seal separated by an oil chamber\* for maximum motor protection

\*In compliance with FDA - Food, Drug Administration - and the annex to G.U. no. 104 of 20/04/73 for oils in contact with food stuffs

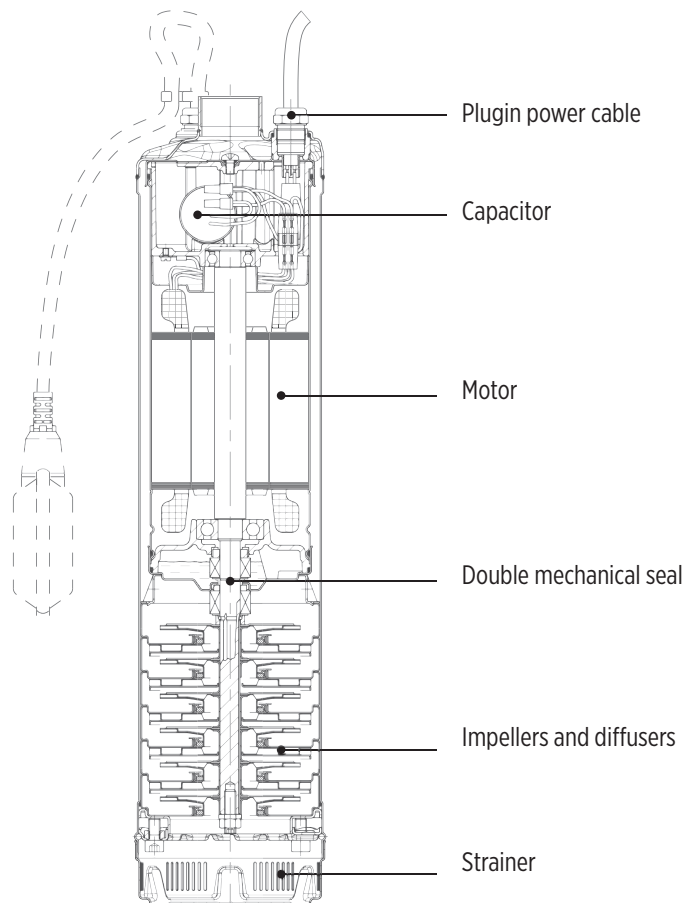

00130250 08/2021

FAMILY CURVES

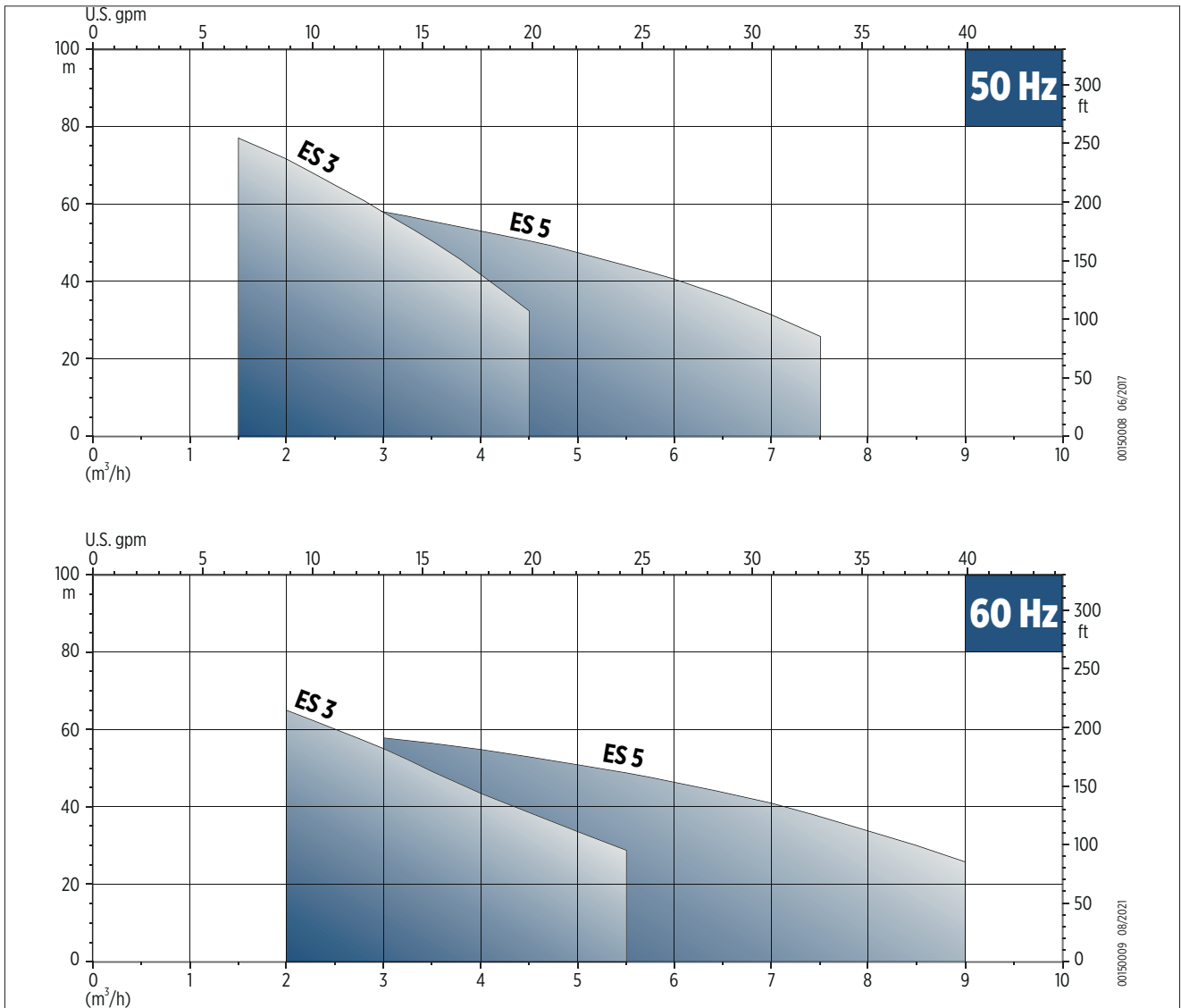

## PUMP IDENTIFICATION CODE

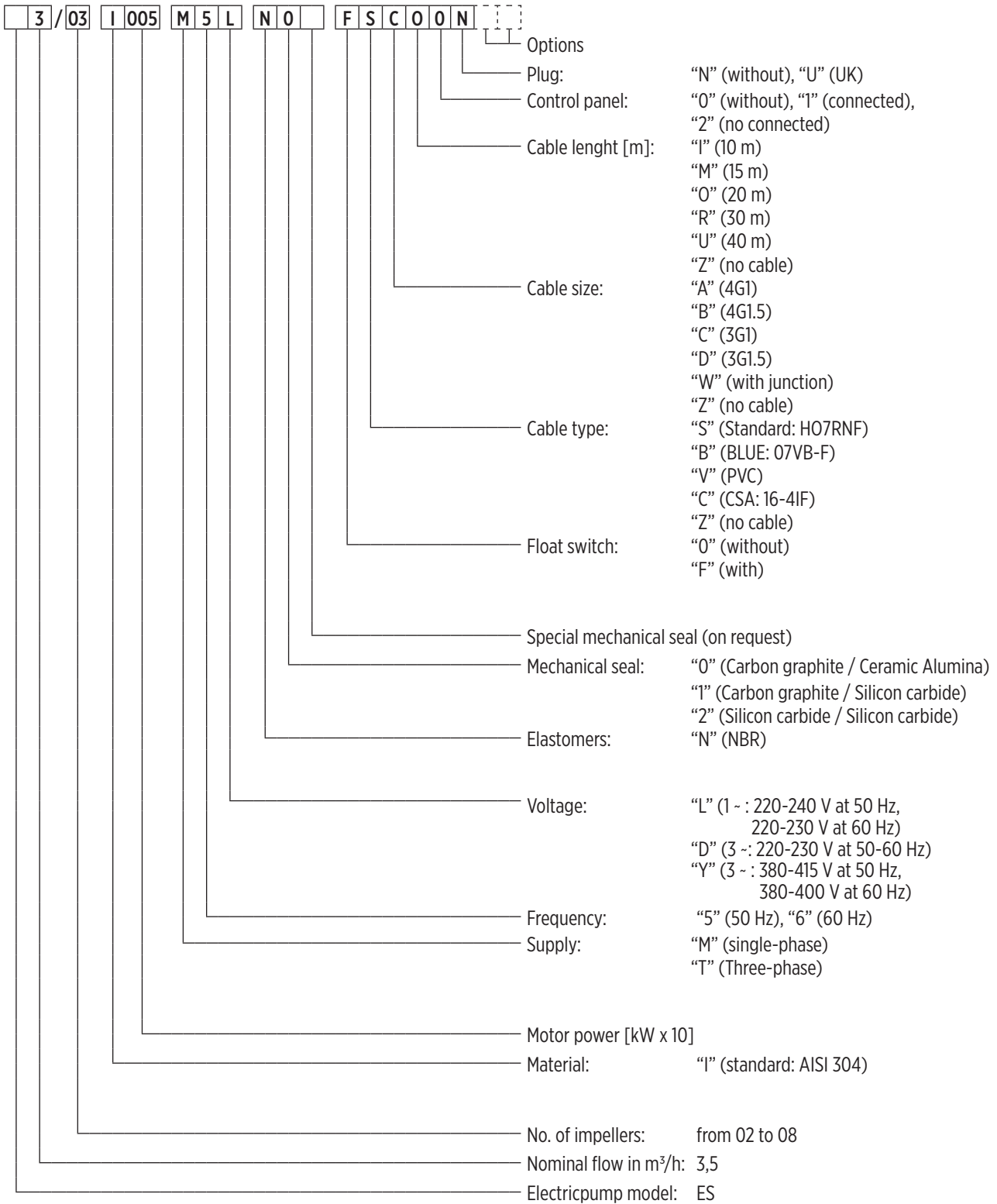

0040005 08/2021

## GENERAL FEATURES

Model	3	5	3	5
Frequency:	50 Hz		60 Hz	
Nominal flow [m <sup>3</sup> /h]	3	5	3	5
Liquid temperature range [°C]	-5 / +40			
Max. D hydraulic [%]	42.3	56.1	42.3	56.1
Range [m <sup>3</sup> /h]	1.5 - 4.5	2.5 - 7.5	2.5 - 5.5	3.0 - 9.0
Max. head [m]	75.5	58.5	69	58
Maximum operating pressure [bar]	10			
Discharge outlet:	1"¼ Rp			
Power cable:	20 m, type H07RN F			
Maximum immersion depth [m]:	17 (with 20m power cable length) 20 (with power cable longer than 20m)			
Maximum allowable amount of sand/Maximum solids size:	50 gr/m <sup>3</sup> , up to 2 mm			
Float switch option:	Single phase version without level regulator			
Motor power [kW]:	0,55 ÷ 1,1kW		0,75 ÷ 1,1kW	
Motor type:	Asynchronous Protection degree: IP68 Insulation class: F			
Motor standard voltage:	Single Phase	220-240 V ± 5 %		220-230V ± 5 %
	Three Phase	380-415 V ± 5 % (220-240 V ± 5 % on request)		380-400V ± 5% (220-230V ± 5 % on request)
Thermal protection	Single phase version: built into the motor up to 1.1 kW Three phase: to be provided into the starter panel by the Installer			
Capacitor:	Built in for single phase version			
Motor frequency of starts:	max. 40 starts/hour (with min. 1 minutes resting time)			

# SPARE PARTS AND MATERIALS

Ref. No.	Spare parts description	Material	Standard	
			ASME	DIN / EN
10.01 *	Screws and flanges for pre-loading	Stainless steel	-	UNI-EN 12165-98
10.02 *	Power cable assembly	Cable: H07RN-F		
		Cable gland: nickel plated brass / NBR		
10.03 *	Seeger-ring	Stainless steel	AISI 304	1.4301
10.04 *	Level control assembly	Cable: H07RN-F		
		Float switch: PP		
		Holding cable plate: PA66		
		Cable gland: nickel plated brass / NBR		
10.05	Capacitor with cables and connectors	-		
10.06	Clamp for capacitor	-		
20.00 *	Outer case	Stainless steel	AISI 304	1.4301
20.01 *	Suction strainer	Stainless steel	AISI 304	1.4301
30.00 *	Motor housing and stator	Stainless steel	AISI 304	1.4301
30.01 *	Upper motor cover	Stainless steel	AISI 304	1.4301
30.02	Upper bearing housing with cover	Aluminum		
30.03 *	Lower motor cover	Stainless steel	AISI 304	1.4301
30.04	Lower bearing cover	Aluminum		
30.05 *	O-Ring	NBR		
30.06 *	Mechanical seals	Ceramic alumina / Carbon graphite / NBR		
30.07	Ball bearings	6202 2Z-C3 / 6303 2Z-C3		
30.08 *	Rotor and pump shaft	Stainless steel	AISI 304	1.4301
30.09 *	Screws, nut and washers	Stainless steel	AISI 304	1.4301
			AISI 316	1.4401
40.00 *	Stage housing and diffuser	Stainless steel	AISI 304	1.4301
40.01 *	Spacer	Stainless steel	AISI 304	1.4301
40.02 *	Floating neck ring	PPS		
40.03 *	Initial stage housing	Stainless steel	AISI 304	1.4301
50.00 *	Impeller	Stainless steel	AISI 304	1.4301
50.01 *	Impeller spacers	Stainless steel	AISI 304	1.4301

\* Spare parts in contact with liquid

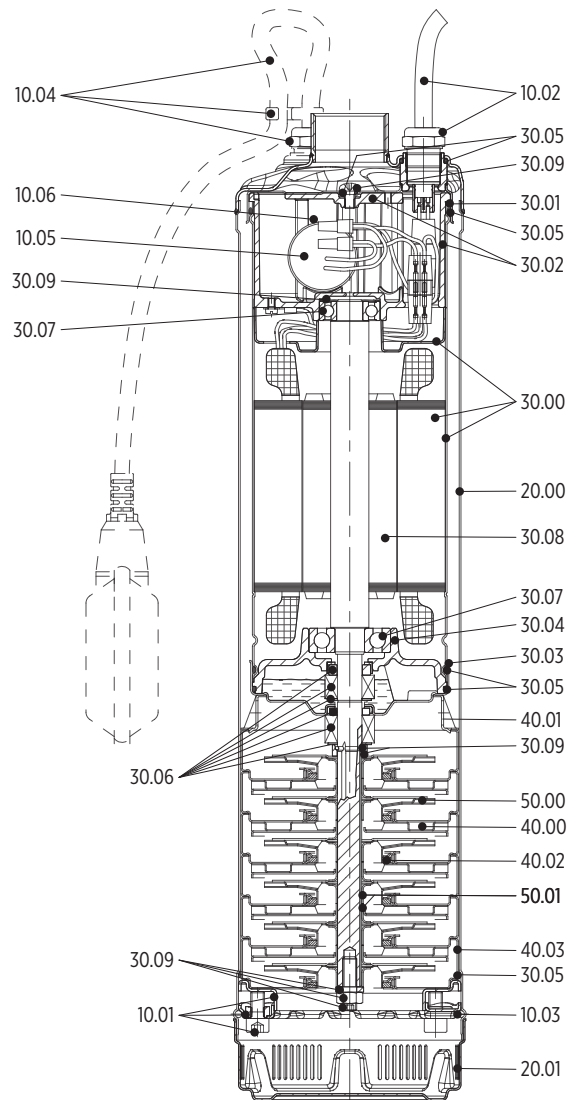

0018028 017268



## PERFORMANCE SELECTION

This section describes **how to select the pump model that better suits your needs.**

The required information are:

- The required flow
- The input and output pressure
- The fluid features (density, viscosity, temperature, chemical aggressiveness and presence of abrasive particles)
- The connection type

Check if the pump piping type selected is able to withstand the maximum working pressure required (pump nominal pressure  $P_N \geq$  application nominal pressure).

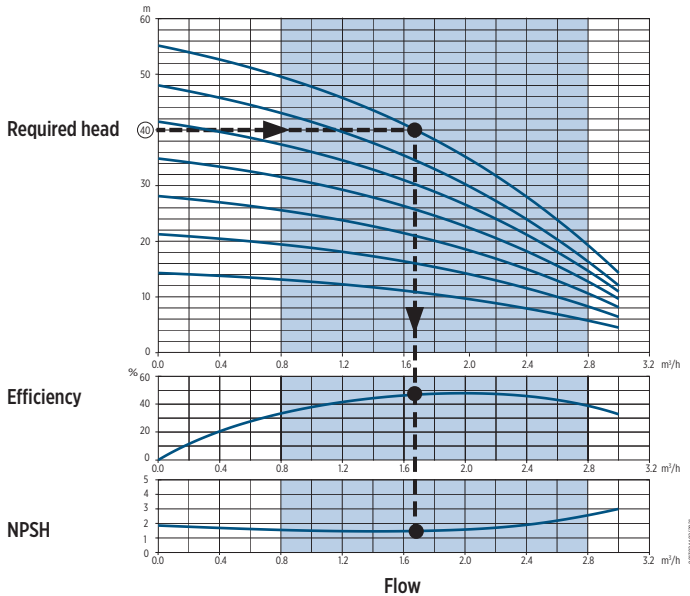

The difference between the outlet required pressure and the input pressure allows to determine the head the pump must supply to the fluid. The duty point is determined crossing the values of flow and head.

For the best selection of multistage pump, proceed in this way:

1. Select the pump family according to the requested flow (close as much as possible to the best efficiency point).
2. Choose the number of stages nearest to the requested head.
3. Draw a vertical line from duty point to determine the absorbed power, the pump efficiency and the NPSH required.

If the viscosity of fluid is significantly different from clean water at ambient temperature, it's necessary to change the selection parameters (contact the manufacturer). Moreover, in case the density or viscosity are higher than water values, it will be necessary to consider a higher power sizing (contact the manufacturer).

### NPSH check:

The available pump input NPSH value must be compared with the pump required value in order to avoid performance losses and wearing of the pump.

The maximum height of the pump from the liquid level (H) can be calculated with the following formula:

$$H = p_b \times 10.2 - NPSH - H_f - H_v - H_s$$

Where:

$p_b$ : Absolute barometric pressure or absolute pressure of the liquid on suction side [bar].

NPSH: Suction head at maximum duty flow rate [m]

$H_f$ : Pressure drop in the suction pipe at maximum flow rate [m]

$H_v$ : Vapour pressure [m] depending on the temperature of the liquid [m]

$H_s$ : Safety margin [m] (minimum 0.5)

If the calculated value is less than "0", the pump must be positioned below the liquid level by the value of H.



# TECHNICAL DATA AND PERFORMANCE CURVES AT 50 HZ

## HYDRAULIC PERFORMANCE

Electric pump model	RATED POWER		Q = DELIVERY														
			l/min 0	16.6	25.0	33.3	42	50.0	58.3	67	75.0	83.3	92	100.0	116.7	125	133.3
			m <sup>3</sup> /h 0	1	1.5	2	2.5	3	3.5	4	4.5	5	5.5	6	7	7.5	8
	US gpm 0	4.4	6.6	8.8	11.0	13.2	15	17.6	19.8	22.0	24.2	26	30.8	33	35.2		
	[kW]	[HP]	H = TOTAL METERS HEAD OF WATER COLUMN [m]														
ES 3/3	0.55	0.75	34		30.5	28.5	26	24	21	17.5	14						
ES 3/4	0.55	0.75	45		40	37.5	34	31	27	23	18						
ES 3/5	0.75	1	56		49	46	42	38	33	27.5	22						
ES 3/6	0.75	1	66.5		58.5	54	49	44	38.5	32	25						
ES 3/7	0.9	1.2	77		67	62	56	50	45	37.5	28						
ES 3/8	1.1	1.5	87		75.5	70	63	56	50.5	42	31						
ES 5/3	0.55	0.75	35				31	30	29	28	27	25.5	23.5	22	17.5	15	
ES 5/4	0.75	1	46				40.5	39	38	36.5	34.5	33	30.5	28	22	18.5	
ES 5/5	0.9	1.2	57				50	48	47.5	45.5	42	40	38	34	27.5	22	
ES 5/6	1.1	1.5	67.5				58.5	56.5	55.5	53	49	46	44	39	31.5	24	

# ES 3 - 50 HZ

## TECHNICAL DATA

Electric pump model		Number of stages	MOTOR POWER		INPUT POWER	Capacitor		RATED CURRENT		
Single-phase	Three-phase		[kW]	[HP]		[kW]	μF	V	Single-phase 220-240 V	Three-phase 220-240 V    380-415 V
ES 3/3	ES 3/3T	3	0.55	0.75	0.63	16	450	3.6	3.12	1.8
ES 3/4	ES 3/4T	4	0.55	0.75	0.81	16	450	4.0	3.5	2.0
ES 3/5	ES 3/5T	5	0.75	1	0.99	20	450	4.7	3.7	2.1
ES 3/6	ES 3/6T	6	0.75	1	1.15	20	450	5.2	4.0	2.3
ES 3/7	ES 3/7T	7	0.9	1.2	1.34	30	450	6.7	4.4	2.5
ES 3/8	ES 3/8T	8	1.1	1.5	1.50	30	450	7.2	4.7	2.7

## DIMENSIONS AND WEIGHTS

Electric pump			Weight* [Kg]		Packaging [mm]		
Single-phase	Three-phase	Lt [mm]	Single-phase	Three-phase	L	B	H
ES 3/3	ES 3/3T	446	12	13.3	720	230	175
ES 3/4	ES 3/4T	470	12.7	13.95	720	230	175
ES 3/5	ES 3/5T	544	14.3	14.45	720	230	175
ES 3/6	ES 3/6T	568	14.8	15	720	230	175
ES 3/7	ES 3/7T	592	17	15.45	720	230	175
ES 3/8	ES 3/8T	616	17.1	16	720	230	175

\* Electric pump weight without float switch

## DIMENSIONAL DRAWINGS

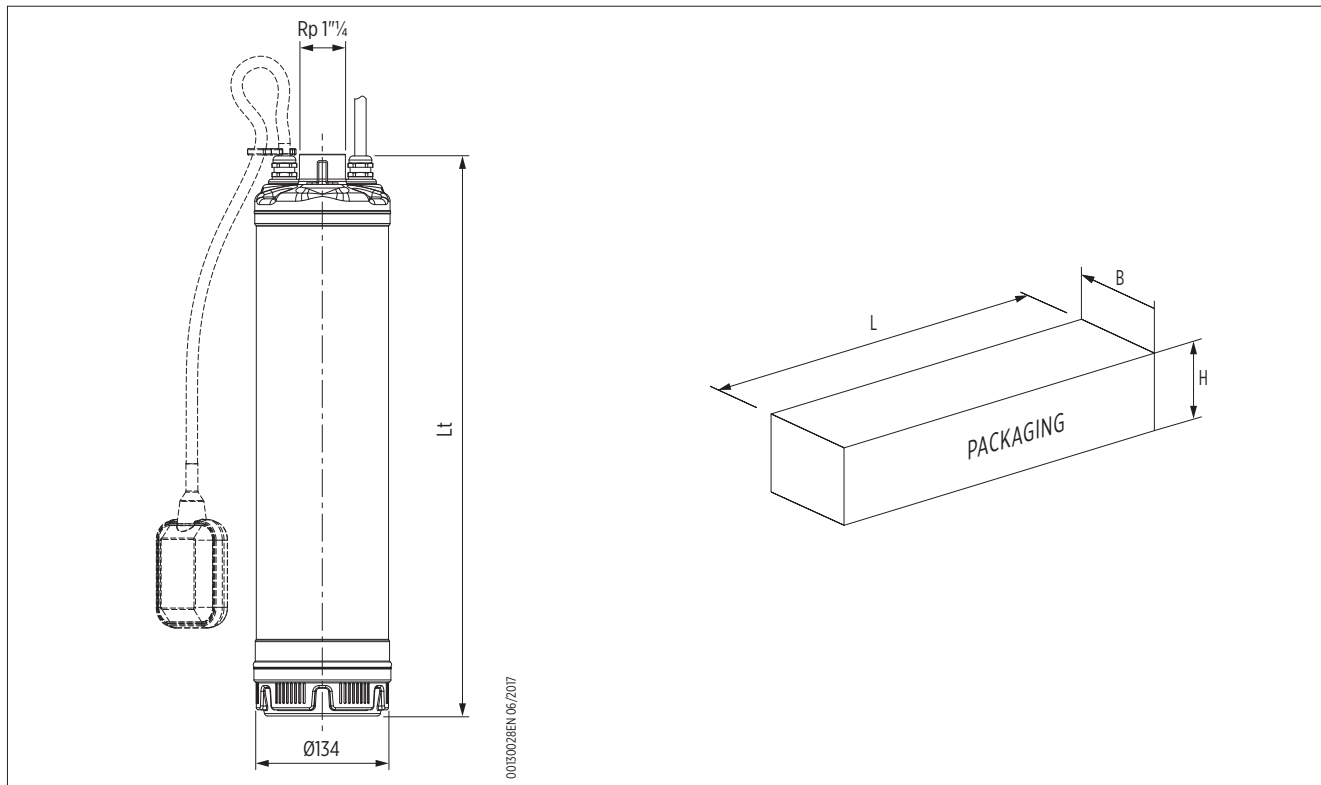

# ES 3 - PERFORMANCE CURVES AT 50 HZ

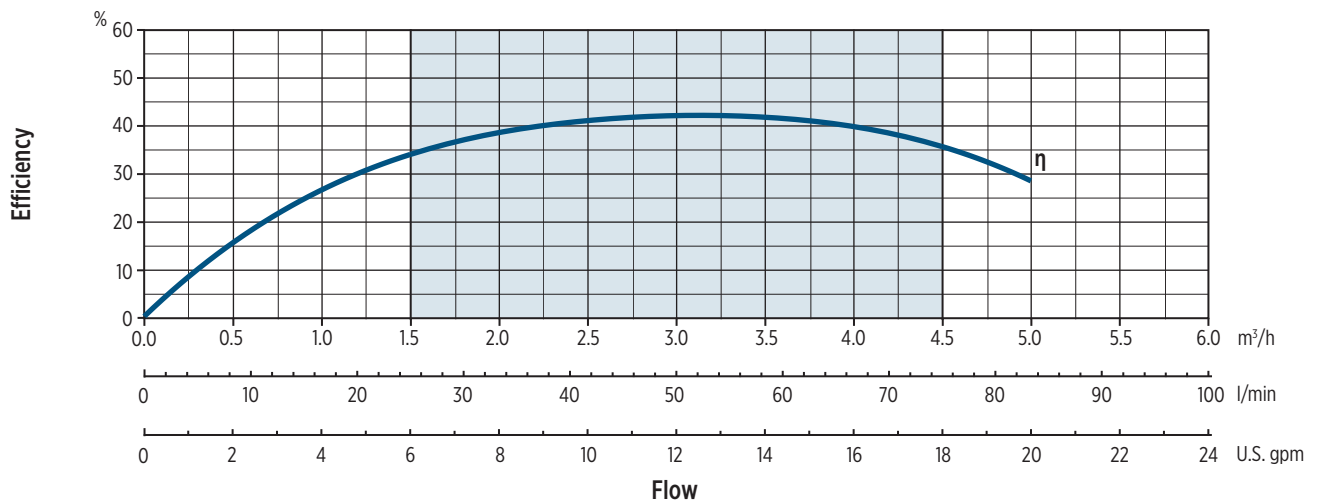
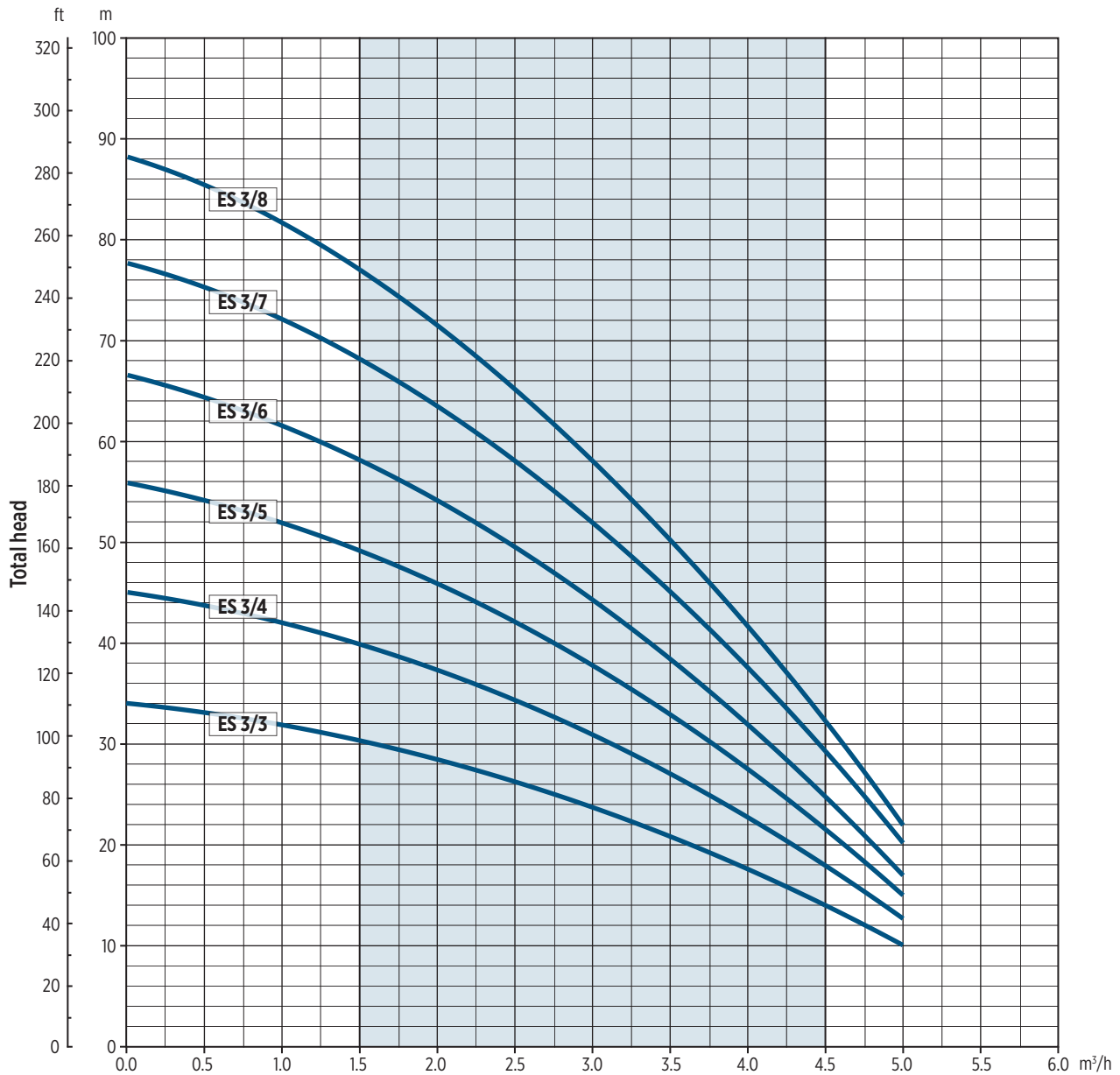

The hydraulic characteristics are guaranteed, according to ISO standard 9906:2012, grade 3B

# ES 5 - 50 HZ

## TECHNICAL DATA

Electric pump model		Number of stages	MOTOR POWER		INPUT POWER	Capacitor		RATED CURRENT		
Single-phase	Three-phase		[kW]	[HP]		[kW]	$\mu$ F	V	Single-phase 220-240 V	Three-phase 220-240 V    380-415 V
ES 5/3	ES 5/3T	3	0.55	0.75	0.84	16	450	4.1	3.5	2.0
ES 5/4	ES 5/4T	4	0.75	1	1.07	20	450	5.0	3.8	2.2
ES 5/5	ES 5/5T	5	0.9	1.2	1.34	30	450	6.6	4.4	2.5
ES 5/6	ES 5/6T	6	1.1	1.5	1.55	30	450	7.4	4.7	2.7

## DIMENSIONS AND WEIGHTS

Electric pump			Weight* [Kg]		Packaging [mm]		
Single-phase	Three-phase	Lt [mm]	Single-phase	Three-phase	L	B	H
ES 5/3	ES 5/3T	446	12	13.3	720	230	175
ES 5/4	ES 5/4T	470	13.5	14	720	230	175
ES 5/5	ES 5/5T	544	15.65	14.5	720	230	175
ES 5/6	ES 5/6T	568	16.15	15	720	230	175

\* Electric pump weight without float switch

## DIMENSIONAL DRAWINGS

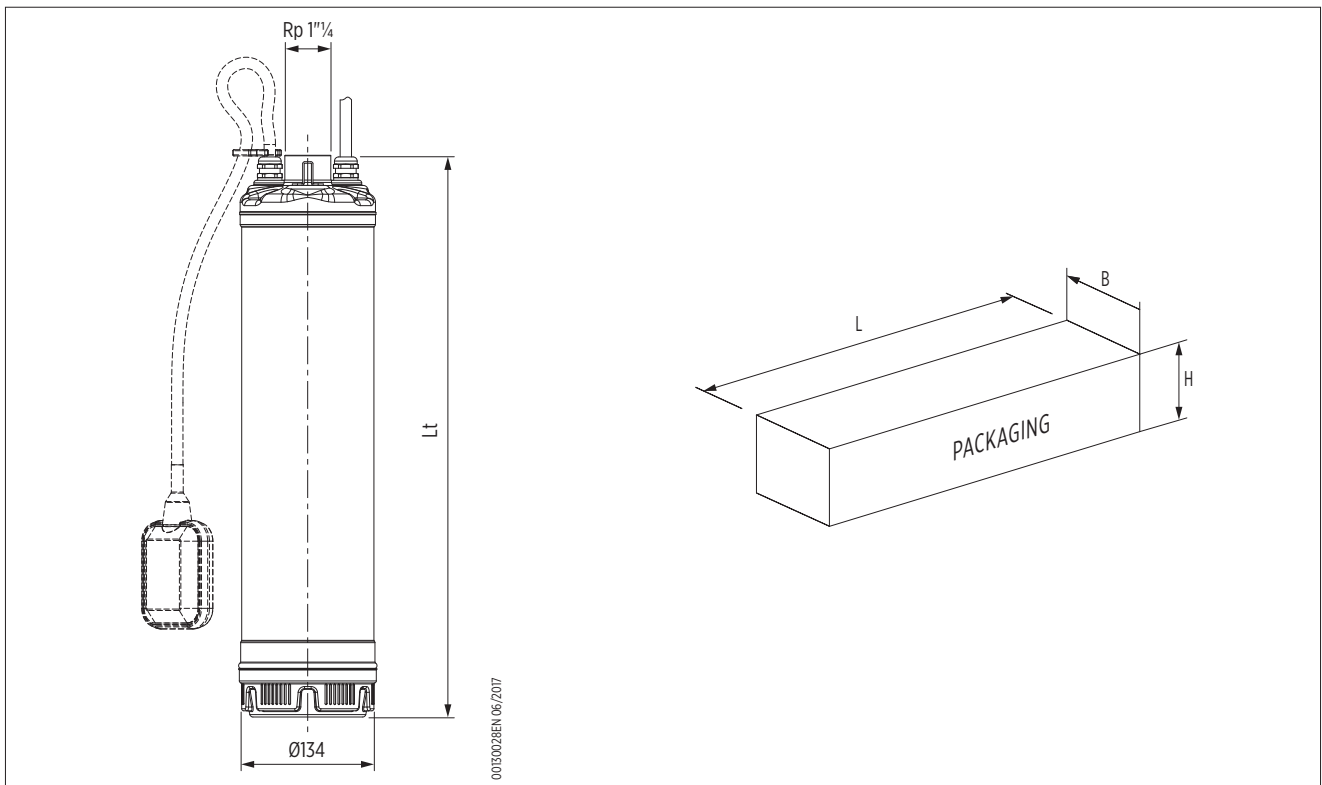

# ES 5 - PERFORMANCE CURVES AT 50 HZ

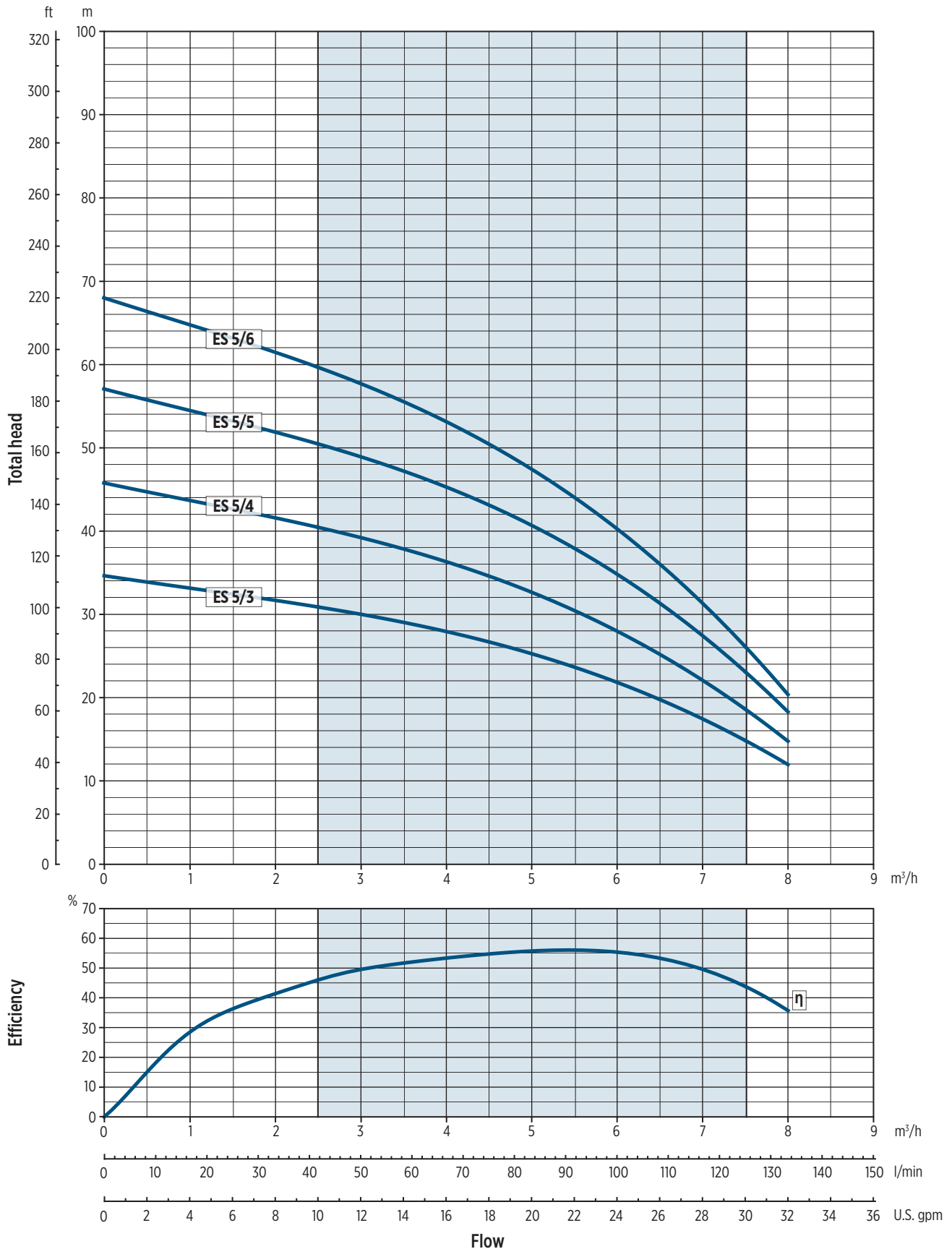

The hydraulic characteristics are guaranteed, according to ISO standard 9906:2012, grade 3B





## TECHNICAL DATA AND PERFORMANCE CURVES AT 60 HZ

### HYDRAULIC PERFORMANCE

Electric pump model	RATED POWER		Q = DELIVERY														
			l/min 0	25.0	33.3	42	50.0	58.3	67	75.0	83.3	92	100.0	116.7	133.3	150	166.6
			m <sup>3</sup> /h 0	1.5	2	2.5	3	3.5	4	4.5	5	5.5	6	7	8	9	10
	US gpm 0	6.6	8.8	11.0	13.2	15	17.6	19.8	22.0	24.2	26	30.8	35.2	39.6	44.0		
[kW]	[HP]	H = TOTAL METERS HEAD OF WATER COLUMN [m]															
ES 3/3	0.75	1	49		43	40.5	37.5	34.5	31	27.5	23	19					
ES 3/4	0.9	1.2	65		55.5	52.5	49	44.5	40	35	29.5	24					
ES 3/5	1.1	1.5	80.5		69	65	60	55	49	43	36.5	29					
ES 5/2	0.75	1	33.5				30	29.5	28.5	28	27	26	25	22	19	15	
ES 5/3	0.9	1.2	50				44	43	42	40.5	39	37.5	36	31.5	27	21	
ES 5/4	1.1	1.5	65.5				58	56.5	55	53	51	49	46.5	41	34	26	

# ES 3 - 60 HZ

## TECHNICAL DATA

Electric pump model		Number of stages	MOTOR POWER		INPUT POWER	Capacitor		RATED CURRENT		
Single-phase	Three-phase		[kW]	[HP]		μF	V	Three-phase		
					Single-phase 220-230 V			220-230 V	380-400 V	
ES 3/3	ES 3/3T	3	0.75	1	1.05	20	450	5.2	4.2	2.4
ES 3/4	ES 3/4T	4	0.9	1.2	1.30	20	450	6.2	4.5	2.6
ES 3/5	ES 3/5T	5	1.1	1.5	1.61	25	450	8.0	5.2	3.0

## DIMENSIONS AND WEIGHTS

Electric pump			Weight* [Kg]		Packaging [mm]		
Single-phase	Three-phase	Lt [mm]	Single-phase	Three-phase	L	B	H
ES 3/3	ES 3/3T	49	13.25	14.2	720	230	175
ES 3/4	ES 3/4T	520	14.7	14.7	720	230	175
ES 3/5	ES 3/5T	544	1.35	15.2	720	230	175

\* Electric pump weight without float switch

## DIMENSIONAL DRAWINGS

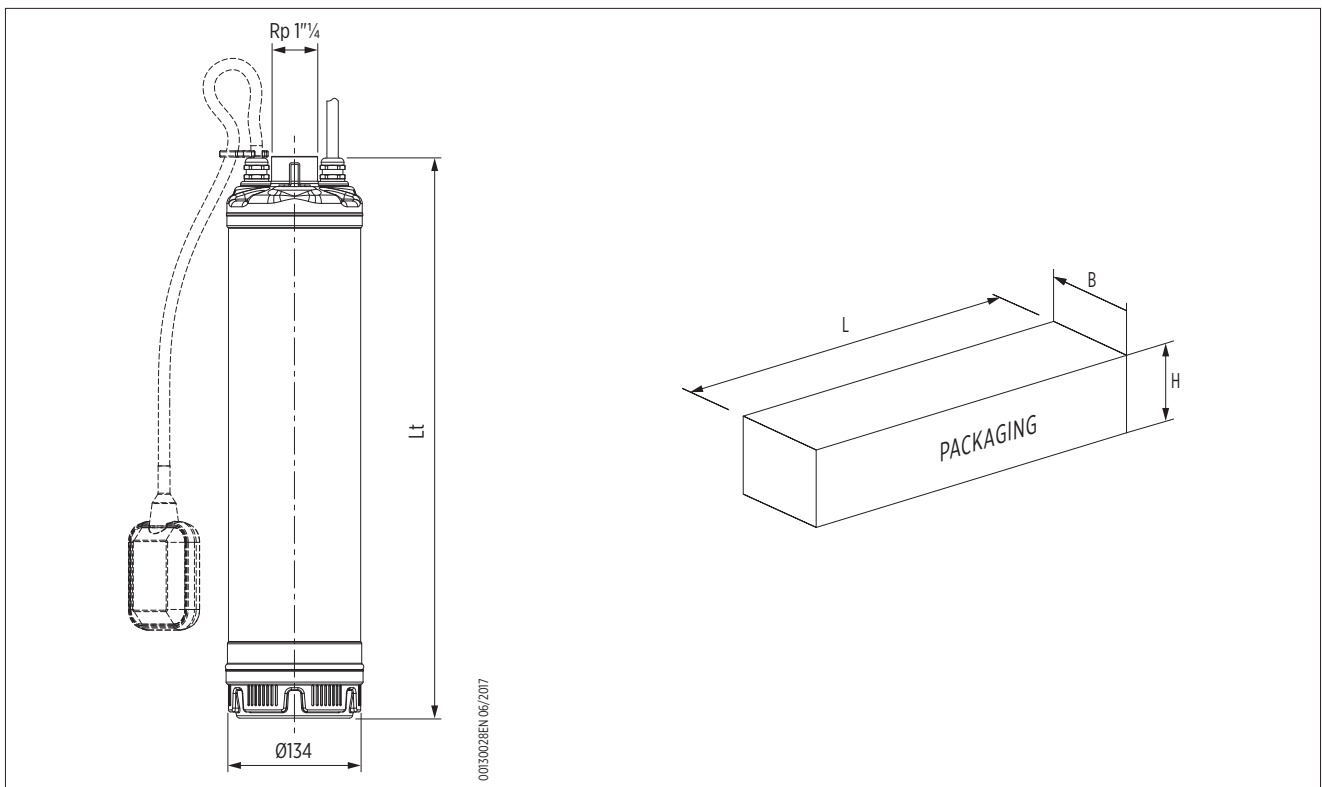

# ES 3 - PERFORMANCE CURVES AT 60 HZ

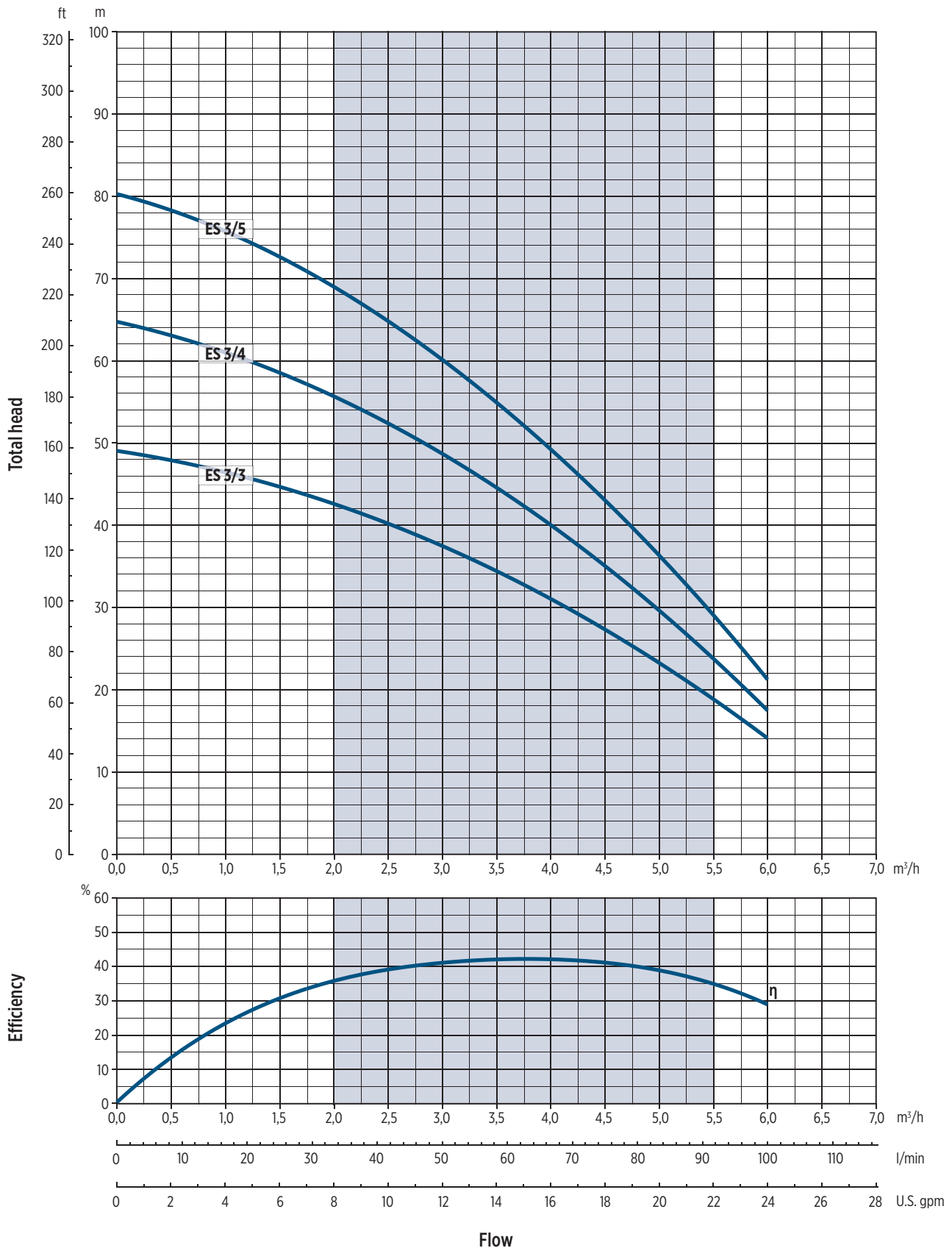

The hydraulic characteristics are guaranteed, according to ISO standard 9906:2012, grade 3B

# ES 5 - 60 HZ

## TECHNICAL DATA

Electric pump model		Number of stages	MOTOR POWER		INPUT POWER	Capacitor		RATED CURRENT		
Single-phase	Three-phase		[kW]	[HP]		$\mu$ F	V	Single-phase 220-230 V	Three-phase	
								220-230 V	380-400 V	
ES 5/2	ES 5/2T	2	0.75	1	1	20	450	5.0	4.0	2.3
ES 5/3	ES 5/3T	3	0.9	1.2	1.35	20	450	4	4.7	2.7
ES 5/4	ES 5/4T	4	1.1	1.5	1.78	25	450	8	5.5	3.2

## DIMENSIONS AND WEIGHTS

Electric pump			Weight* [Kg]		Packaging [mm]		
Single-phase	Three-phase	Lt [mm]	Single-phase	Three-phase	L	B	H
ES 5/2	ES 5/2T	470	14	14	720	230	175
ES 5/3	ES 5/3T	494	14.2	14.2	720	230	175
ES 5/4	ES 5/4T	518	15.85	14.7	720	230	175

\* Electric pump weight without float switch

## DIMENSIONAL DRAWINGS

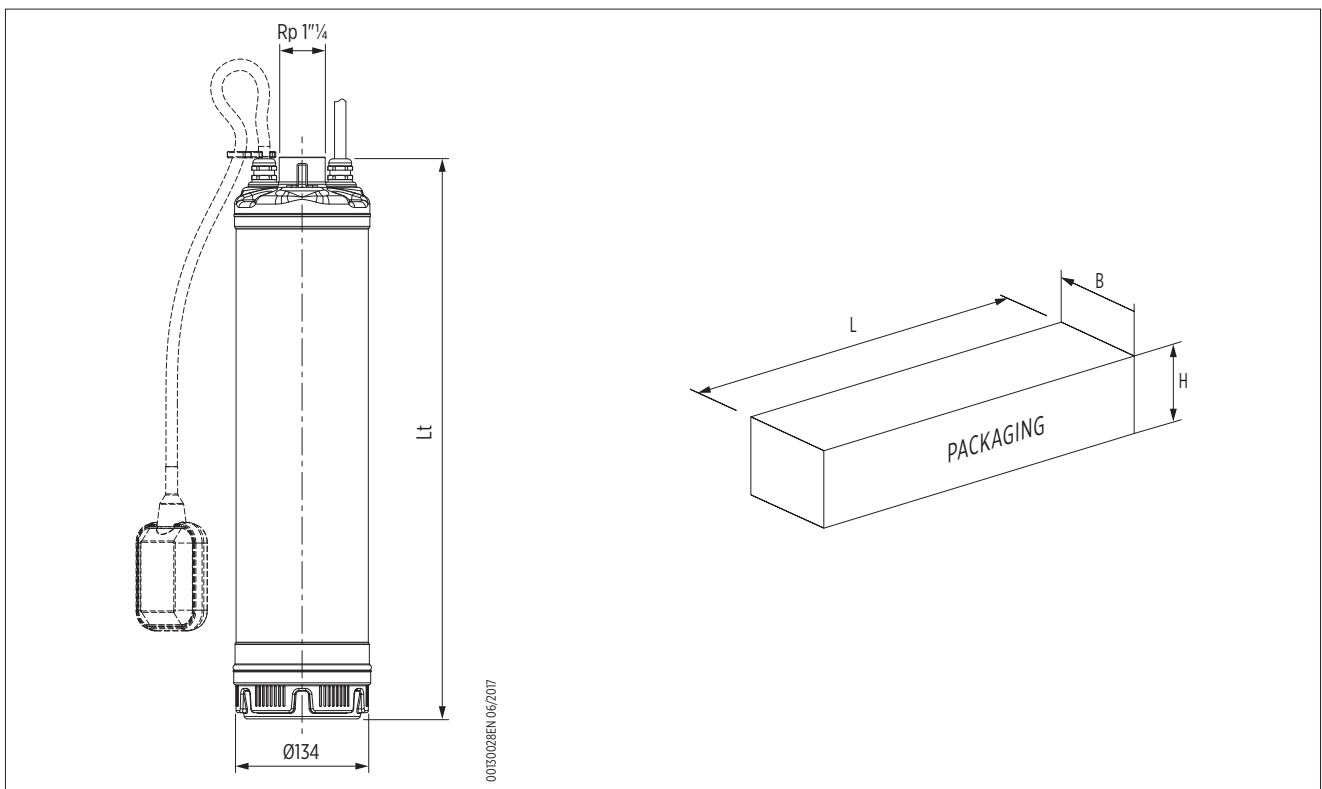

# ES 5 - PERFORMANCE CURVES AT 60 HZ

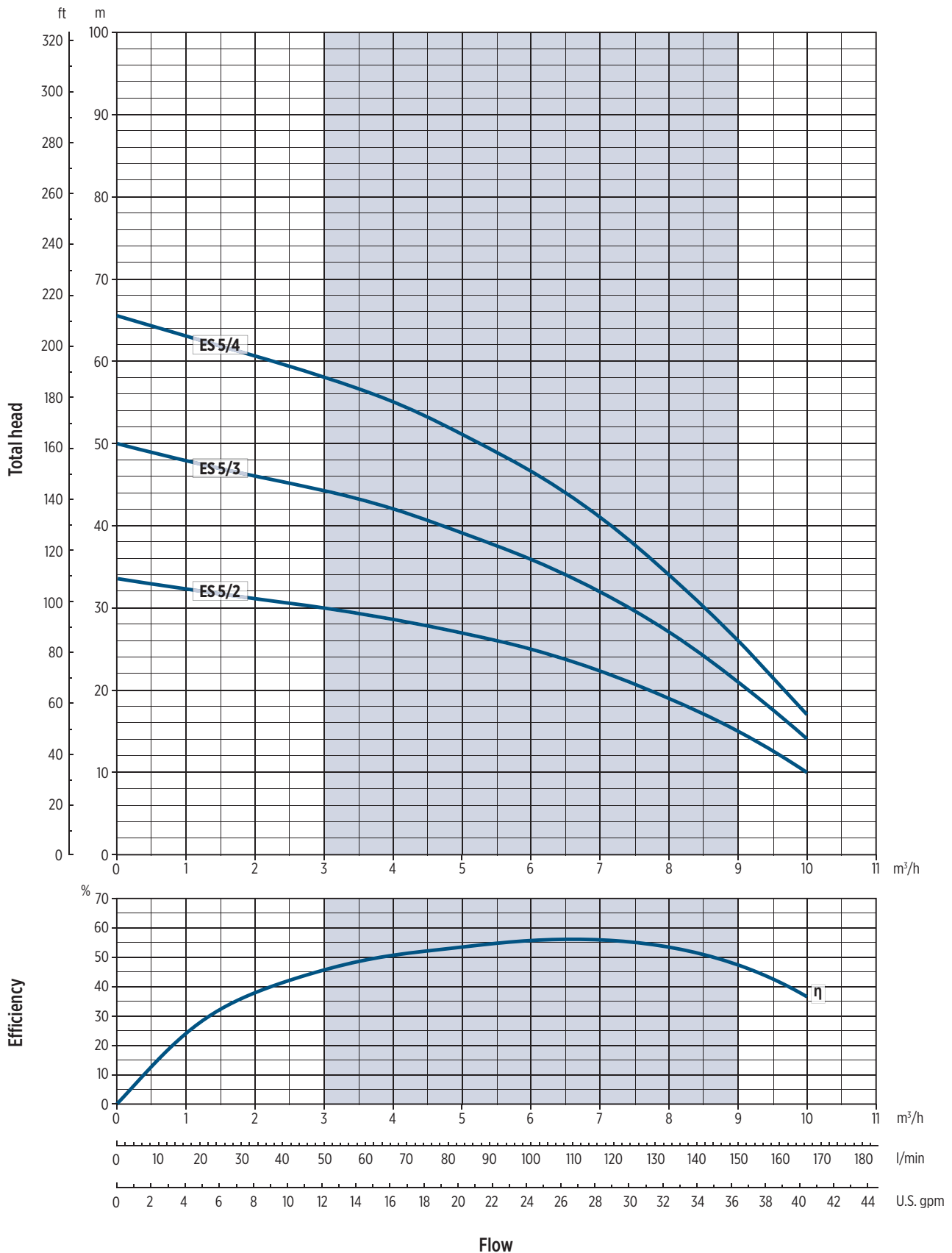

The hydraulic characteristics are guaranteed, according to ISO standard 9906:2012, grade 3B

## ORDERING INFORMATION

Frequency	Pump model	Stages	Single-phase version without float switch	Single-phase version with float switch	Three-phase version 3X230V	Three-phase version 3X400V
50 Hz	ES 3	03	ETH10534300	ETH10534301	ETH10534703	ETH10534700
		04	ETH10534315	ETH10534316	ETH10534719	ETH10534715
		05	ETH10534330	ETH10534331	ETH10534737	ETH10534730
		06	ETH10534345	ETH10534346	ETH10534749	ETH10534745
		07	ETH10534360	ETH10534361	ETH10534762	ETH10534760
		08	ETH10534375	ETH10534376	ETH10534779	ETH10534775
	ES 5	03	ETH10554320	ETH10554321	ETH10554719	ETH10554715
		04	ETH10554335	ETH10554336	ETH10554732	ETH10554730
		05	ETH10554350	ETH10554351	ETH10554748	ETH10554745
		06	ETH10554365	ETH10554366	ETH10554764	ETH10554760

Frequency	Pump model	Stages	Single-phase version without float switch	Single-phase version with float switch	Three-phase version 3X220V	Three-phase version 3X380V
60 Hz	ES 3	03	ETH10534302	ETH10534303	ETH10534704	ETH10534701
		04	ETH10534317	ETH10534318	ETH10534720	ETH10534716
		05	ETH10534332	ETH10534333	ETH10534738	ETH10534731
	ES 5	02	ETH10554305	ETH10554306	ETH10554704	ETH10554700
		03	ETH10554322	ETH10554323	ETH10554720	ETH10554716
		04	ETH10554337	ETH10554338	ETH10554738	ETH10554731

## CATALOG REVISION CHANGE NOTICE

Rev. No.	Changes	Page
02	Modification of the description of pump	2, 3
	Modification and updating of section "Materials/Fluids compatibility"	4
	Updating of "Technical and Dimensional data"	6, 8, 12, 14
03	Updating of "Available on request" section	3
	Adding of new section "Spare parts and Materials table"	5
	Adding of Three-phase 220-240 V values in "Technical data" of ES 3-5 at 50 Hz	8-9
	Modification of performance curves of "ES 3 - 50 Hz"	9
04	Updating of "Spare parts and material table"	5
05	Modification "Electric pump identification code"	4
	Updating of tables "Dimensions and weights"	8, 10, 14, 16
06	Updating general description	2 - 5
	Updating "Family curves"	3
	Updating of "Pump identification code"	4
	Added "Performance selection"	7
	Updating "Hydraulic performance" 50 Hz	9
	Added "ordering information"	20





**Franklin Electric**



00103780 EN REV.06\_09-2021

Single member - Company subject to the control and coordination of Franklin Electric Co., Inc.  
Franklin Electric reserves the right to amend specification without prior notice.

Geoquip Water Solutions Ltd

[www.geoquipwatersolutions.com](http://www.geoquipwatersolutions.com)

Tel : 01473 462 046